

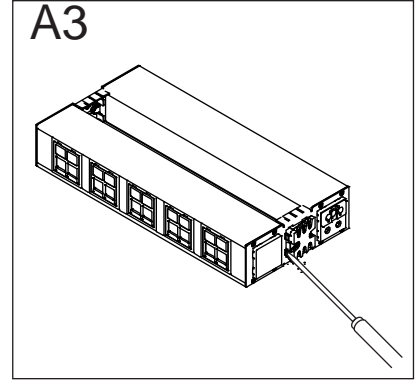

**ES** - Tensión nominal: 125/230V. Intensidad: 3A-16A AC 50/60Hz. Este producto debe ser instalado por un profesional cualificado. La instalación debe realizarse en una línea correctamente protegida contra sobrecarga, cortocircuitos y derivación a tierra. No obedecer a esta norma puede ser peligroso. No desmontar el producto. Este producto debe utilizarse exclusivamente en interiores. IBConnect no se hace responsable de los daños ocasionados por una manipulación indebida del producto. Cualquier reparación del producto en garantía se hará efectiva en las instalaciones de IBConnect. **EN** - Rated voltage: 125/230V Intensity: 3A-16A AC 50/60Hz. This product must be installed by a qualified professional. The installation must be done in one line correctly protected against overload, short-circuits and grounding. Failure to obey this rule can be dangerous. Do not disassemble the product. This product should be used exclusively indoors. IBConnect is not responsible for damages caused by improper handling of the product. Any repair of the product under warranty will be effective at IBConnect facilities. **FR** - Tension nominale: 125/230V. Intensité: 3A-16A AC 50/60Hz. Ce produit doit être installé par un professionnel qualifié. L'installation doit être effectuée sur une ligne correctement protégée contre la surcharge, les courts-circuits et la mise à la terre. Ne pas respecter cette règle peut être dangereux. Ne pas démonter le produit. Ce produit doit être utilisé exclusivement en intérieur. IBConnect n'est pas responsable des dommages causés par une mauvaise manipulation du produit. Toute réparation du produit sous garantie sera effectuée chez IBConnect. **DE** - Nennspannung: 125/230V Stromstärke: 3A-16A AC 50/60Hz. Die Installation darf nur durch eine ausgebildete Elektrofachkraft erfolgen. Der Anschluss muss ordnungsgemäß geerdet und gegen Überlast und Kurzschluss gesichert werden. Die Installation darf nur durch eine ausgebildete Elektrofachkraft erfolgen. Das Produkt darf nicht geöffnet werden und ist ausschließlich für den Einsatz in geschlossenen Räumen konzipiert. IBConnect übernimmt keine Verantwortung für jedwede Schäden, die durch unsachgemäße Verwendung entstehen können. Jegliche Reparaturen im Rahmen der zugesicherten Garantiesprüche dürfen nur durch IBConnect durchgeführt werden. **IT** - Tensione nominale: 125/230V Corrente: 3A-16A AC 50/60Hz. Questo prodotto deve essere installato da un professionista qualificato. L'installazione deve essere su una linea adeguatamente protetta da sovraccarico, cortocircuito e guasto a terra. Il mancato rispetto di questa norma può essere pericoloso. Non smontare il prodotto. Questo prodotto deve essere utilizzato solo in ambienti interni. IBConnect non può essere ritenuto responsabile per eventuali danni causati da un uso improprio di questo prodotto. Il mancato rispetto di questo regolamento può essere pericoloso. Qualsiasi riparazione del prodotto in garanzia sarà effettuata presso la sede di IBConnect. **RU** - Номинальное напряжение: 125/230 В. Номинальный ток: 3Ампер-16Ампер AC 50/60 Гц. Этот продукт должен быть установлен квалифицированным специалистом. Электрическая линия должна быть защищена от перегрузки, короткого замыкания и заземлена. Опасно для жизни, если это правило не соблюдается. Этот продукт предназначен только для использования во внутренних помещениях. IBConnect не несет ответственности за ущерб, причиненный неправильным обращением с продуктом. Любой ремонт изделия по гарантии будет осуществляться силами IBConnect.

## A

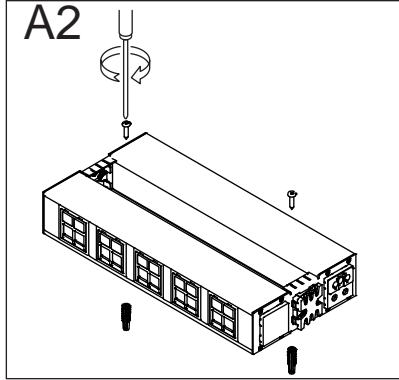
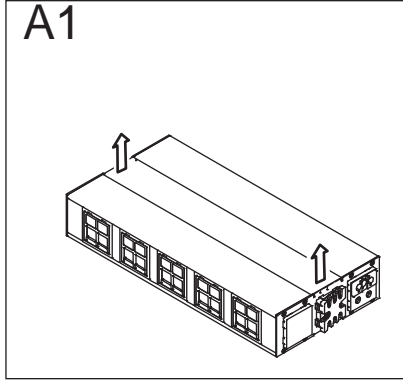

## B

**INSTALCIÓN CON CONECTORES DE DATOS RJ45**

**INSTALLATION WITH RJ45 CONNECTORS**

**INSTALLATION AVEC DES CONNECTEURS RJ45**

**INSTALLATION MIT RJ45 DATENANSCHLÜSSEN**

**INSTALLAZIONE CON CONNETTORI RJ45**

**ИНСТАЛЛЯЦИЯ С РАЗЪЕМАМИ RJ45**

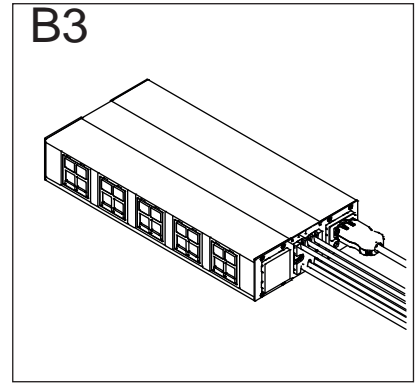
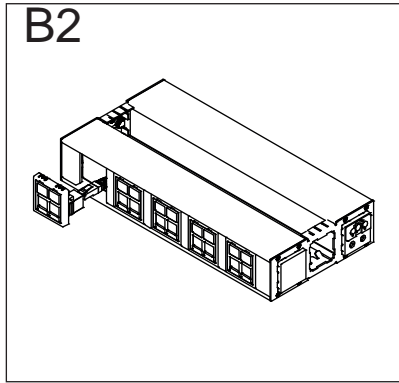
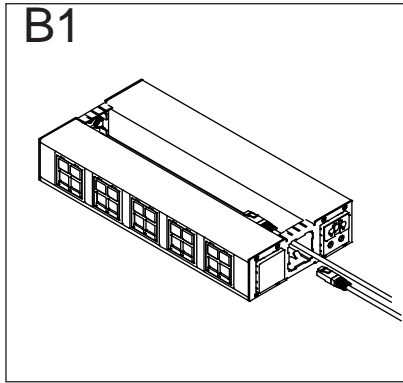

## C

**INSTALCIÓN ÚNICAMENTE CON TOMAS ELÉCTRICAS**

**INSTALLATION WITH ELECTRICAL OUTLETS ONLY**

**INSTALLATION AVEC PRISES DE COURANT UNIQUEMENT**

**INSTALLATION AUSSCHLIEßLICH MIT STROMANSCHLÜSSEN**

**INSTALLAZIONE SOLO CON PRESE ELETTRICHE**

**ИНСТАЛЛЯЦИЯ ТОЛЬКО С ЭЛЕКТРИЧЕСКОЙ РОЗЕТКОЙ**

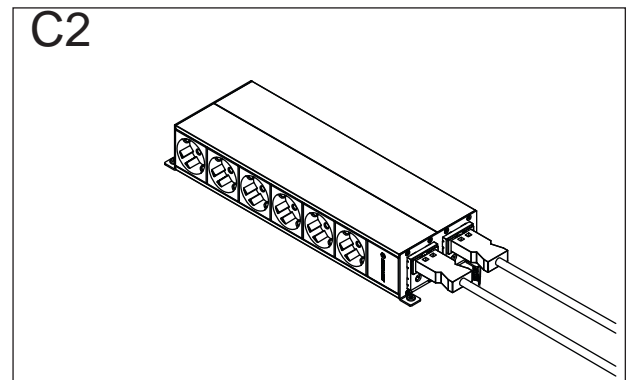
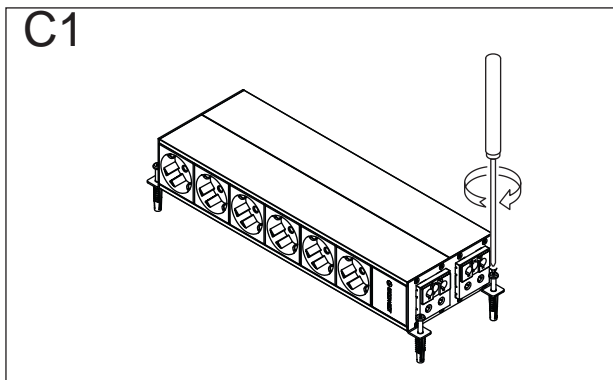

INTERCAMBIO DE  
MÓDULOS  
MULTIMEDIA

EXCHANGE OF  
MULTIMEDIA  
MODULES

ÉCHANGE DES  
MODULES  
MULTIMÉDIA

AUSTAUSCH VON  
MULTIMEDIA-  
MODULEN

SCAMBIO DI  
MODULI MULTIMEDIA

ЗАМЕНА МУЛЬТИМЕ-  
ДИЙНЫХ МОДУЛЕЙ

45x45 ⇒ 45x45

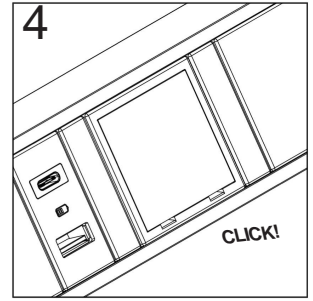
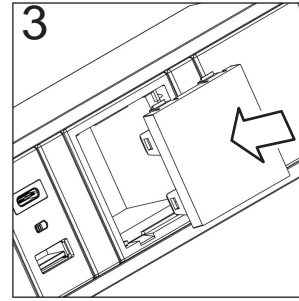
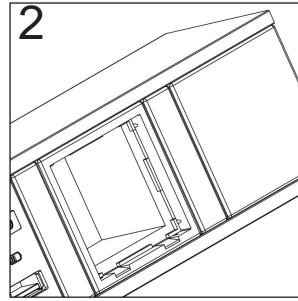
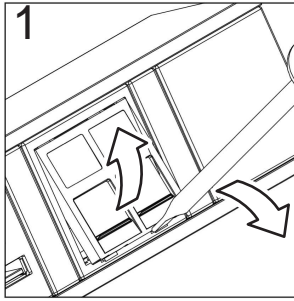

45x45 ⇒ 2x(22,5x45)

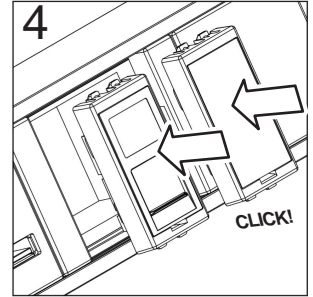
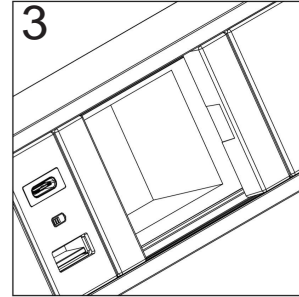
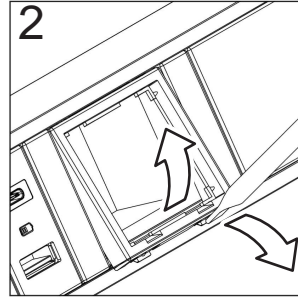
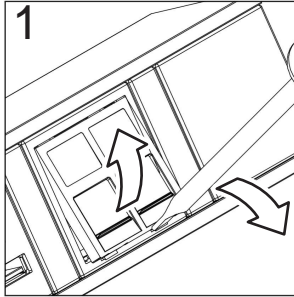

ACCESO DIRECTO  
POSTERIOR A  
MÓDULOS  
MULTIMEDIA

DIRECT REAR ACCESS  
TO MULTIMEDIA  
MODULES

ACCÈS DIRECT  
ARRIÈRE AUX  
MODULES  
MULTIMÉDIA

DIREKETER ZUN-  
GANG  
ZU DEN MULTIMEDIA-  
MODULEN

ACCESO DIRETTO  
POSTERIORE AI  
MODULI MULTIMEDIA

ДОСТУП К МУЛЬТИ-  
МЕДИЙНЫМ МОДУ-  
ЛЯМ С ТЫЛЬНОЙ  
СТОРОНЫ

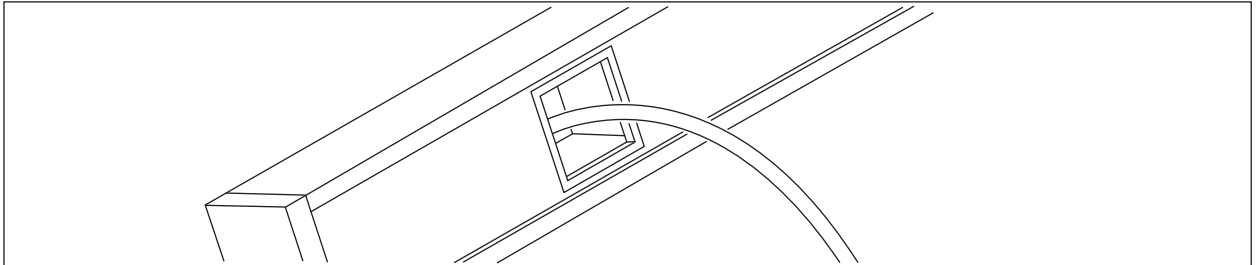

ONLY FOR PRODUCTS WITH TYPE-G SOCKET - FUSE REPLACEMENT - DISCONNECT POWER BEFORE HANDLING!

